

Hydraulic and air coupler with zero hydraulic oil leak with special seal at tip section

Pal coupler socket
Hydraulic pressure 7 MPa & air
model **WVP-2FSL**

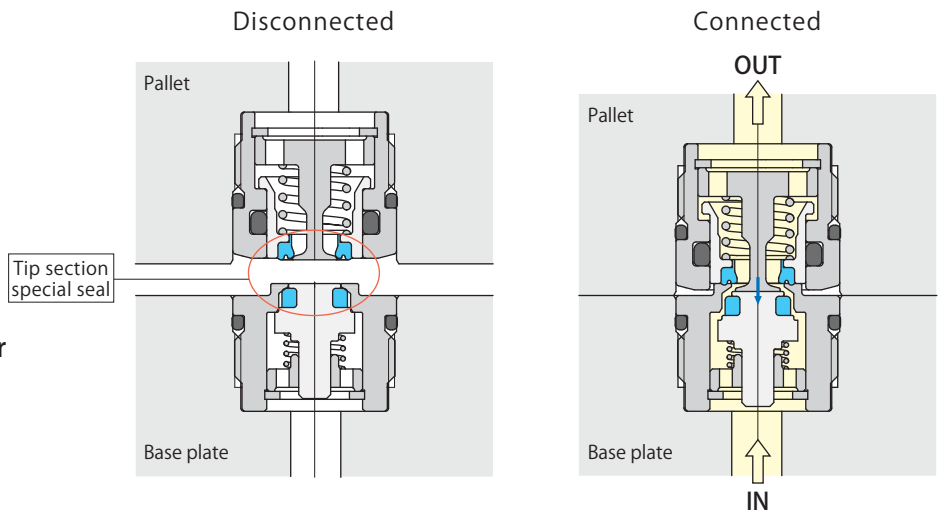

Pal coupler plug
Hydraulic pressure 7 MPa & air
model **WVP-2FPL**

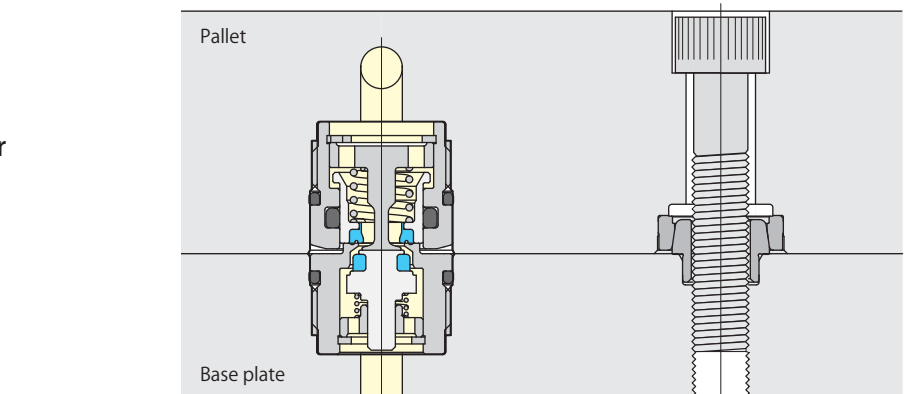

Specifications

- Special soft seal at tip section enables plug (WVP-2FPL) to be pressurized under disconnected state. Socket (WVP-2FSL) can retain residual pressure of up to 0.3 MPa.
- Special seal installed on the tip of coupler socket and coupler plug can minimize the intrusion of air and spill of working fluid during connection and disconnection, furthermore, it prevents corruption of coolant by being miscible with spilled working fluid and air contamination of clamp circuit.
- Height of coupler is maintained low in order to reduce thickness of pallet.
- This model is designed to use on flat mating faces with no protrusion from mount face.
- The parts in the coupler are corrosion prevented (plating or stainless) and oil and air can be applied as a fluid.

Pressure range	0–7 MPa	Circuit symbol
Proof pressure	10.5 MPa	
Orifice area	10.2 mm ²	
Fluid used	General mineral based hydraulic oil (ISO-VG32 equivalent) & air	
Allowable eccentricity	±0.5 mm	
Allowable inclination	0.3° or less	
Reactive force*	113 N per 1 MPa fluid pressure	
	Max. spring force for no pressure 40 N	
Operating temperature	0–70 °C	
Mass	WVP-2FSL : 31 g WVP-2FPL : 29 g	

* : Reactive force (N) = Fluid pressure (MPa) × 113 + 40

WVP-2FSL

Hydraulic pressure 7 MPa & air socket
Recommended tightening torque : 15 N·m

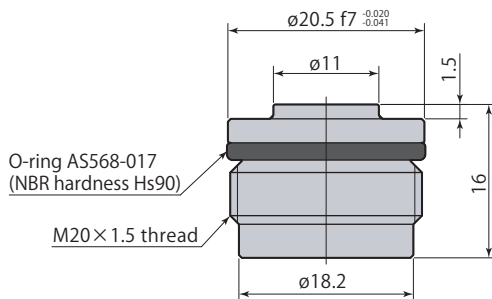
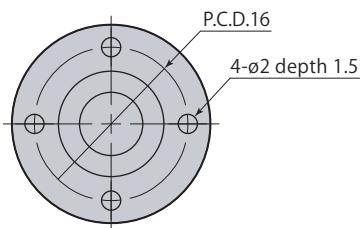
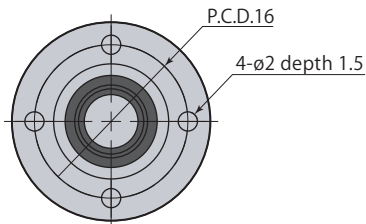
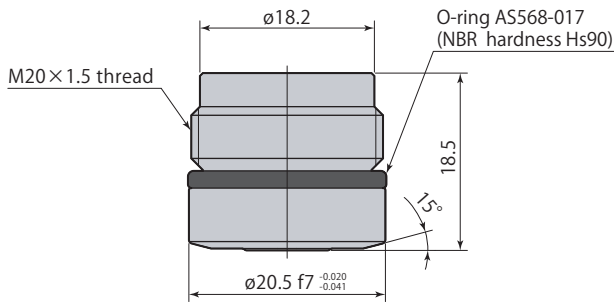

WVP-2FPL

Hydraulic pressure 7 MPa & air plug
Recommended tightening torque : 15 N·m

Dimensions

Mounting details

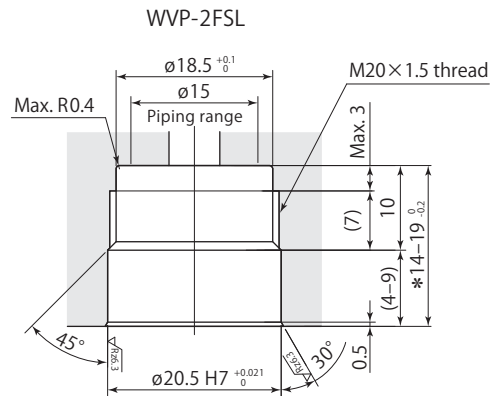

* :When using Pal fix as a set, be sure to set depth to 19.0. Refer to pages →64-75 for details on Pal fix.

Mounting details

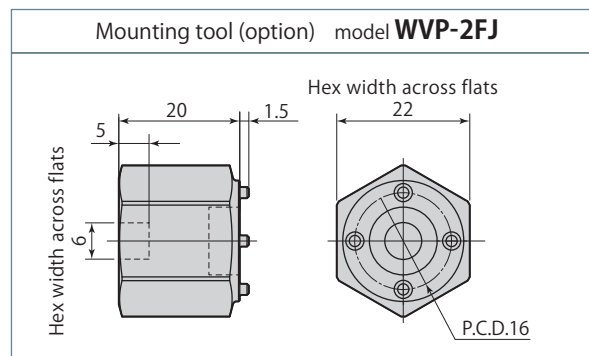
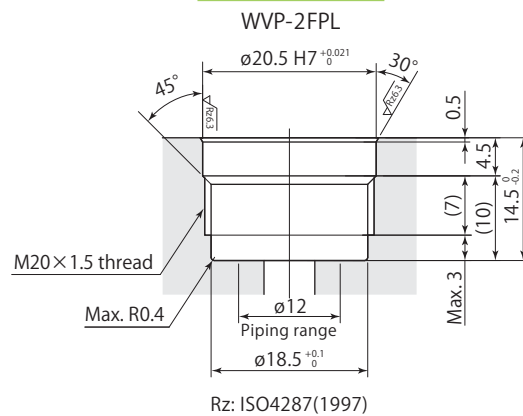

Caution in use

- Stop supplying fluid during disconnection and connection operations. Disconnecting or connecting coupler while fluid is flowing results in the leakage.
- Coupler has no built in filter. Ensure that foreign substances on connecting surfaces are removed by blowing air before connecting to prevent intrusion of foreign substances into piping.
- Make sure air bleeding in the hydraulic circuit is perfectly done when installation.
- Provide the stopper and the guide as shown in the diagram to protect coupler from damage unless it is used in combination with Pal fix. Do not use a coupler as a guide or stopper when connecting. It may cause the damage. Install the stopper to have the dimension 33.5 (See diagram on the right). Observe allowable eccentricity and inclination value when installing the guide. (Refer to page →84 for details on allowable eccentricity and inclination value.)

Mounting sample without Pal fix

