

Compact coupler that has less reactive force when connecting by means of a pilot check valve

7 MPa Pilot coupler plug

model **WVP-2EPL**

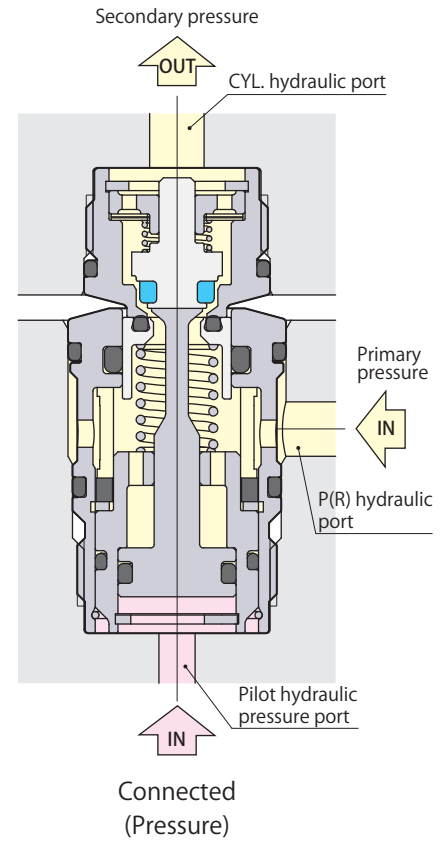
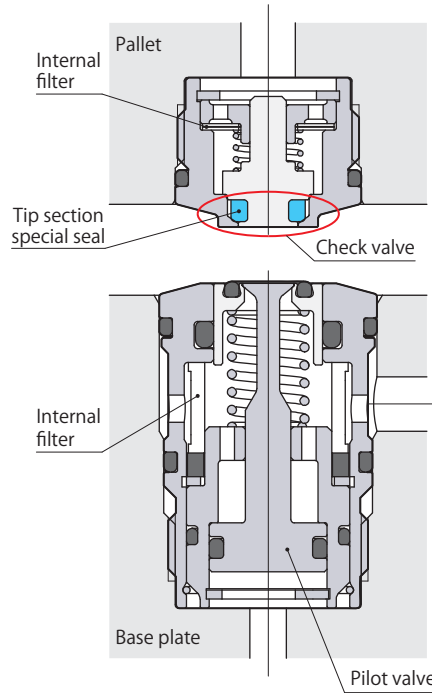

7 MPa Pilot coupler socket

model **WVP-2ESL**

Disconnected

Connected (Pressure)

Specifications

- A pilot check mechanism enables the reactive force when connecting to lower.

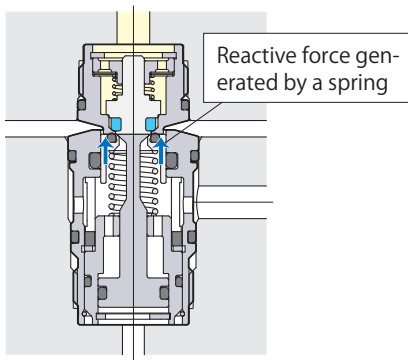

- Unique seal on the tip of coupler ensures a long-term retaining the circuit pressure even after disconnection.
- Filter is fitted inside coupler to prevent intrusion of metal chips and debris into hydraulic circuit.

Pressure range	1–7 MPa	Circuit symbol OIL 7MPa Secondary pressure retainable
Proof pressure	10.5 MPa	
Orifice area	10.2 mm ²	
Fluid used	General mineral based hydraulic oil (ISO-VG32 equivalent)	
Allowable eccentricity	±0.5 mm	
Allowable inclination	0.3° or less	
Reactive force	Spring force when connected 28 N	
	Reactive force when pressurized $113 \times P^{*1} + 36 \text{ N}$	
Pilot pressure	$0.4 \times P^{*2} + 0.1 \text{ MPa}$ or more	
Operating temperature	0–70 °C	
Mass	WVP-2EPL : 29 g	WVP-2ESL : 82 g

*1:P = Primary side hydraulic pressure (MPa)

*2:P = Secondary side hydraulic pressure (MPa)

WVP-2EPL

Hydraulic pressure 7MPa plug
Recommended tightening torque : 15 N·m

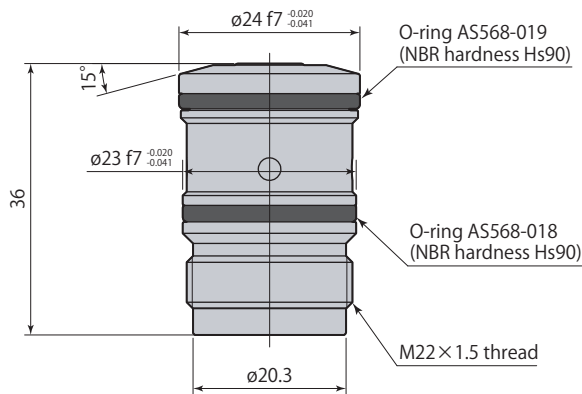
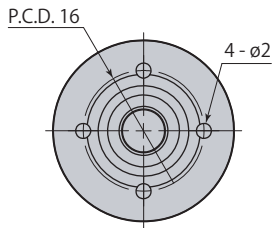
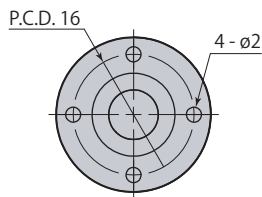
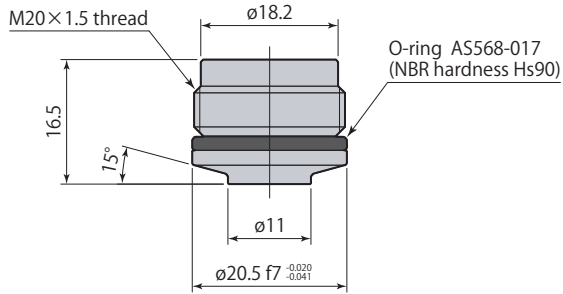

WVP-2ESL

Hydraulic pressure 7MPa socket
Recommended tightening torque : 15 N·m

Dimensions

Mounting details

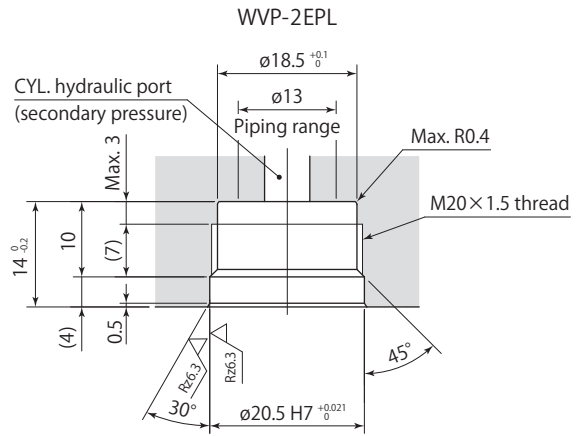

Mounting details

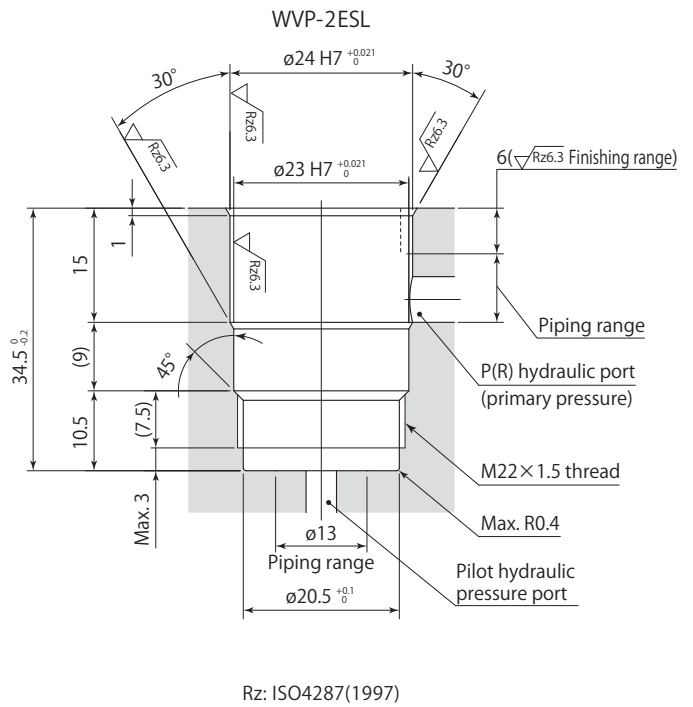

Rz: ISO4287(1997)

- Do not supply pressure to P port (primary) and pilot port under disconnected state or during connecting and disconnecting action.
- No check valve provided in a socket. Do not supply pressure when coupler disconnected state.
- Make sure air bleeding in the hydraulic circuit is perfectly done when installation.
- Reactive force generates when primary pressure is supplied. Locking device which exerts bigger force than reactive force should be mounted after couplers are connected.

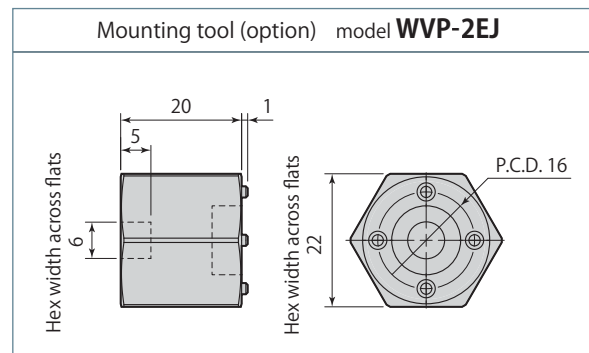

Clamp pressure holding action

- ① Disconnected state
- ② Connecting
- ③ Build pressure-1
- ④ Build pressure-2

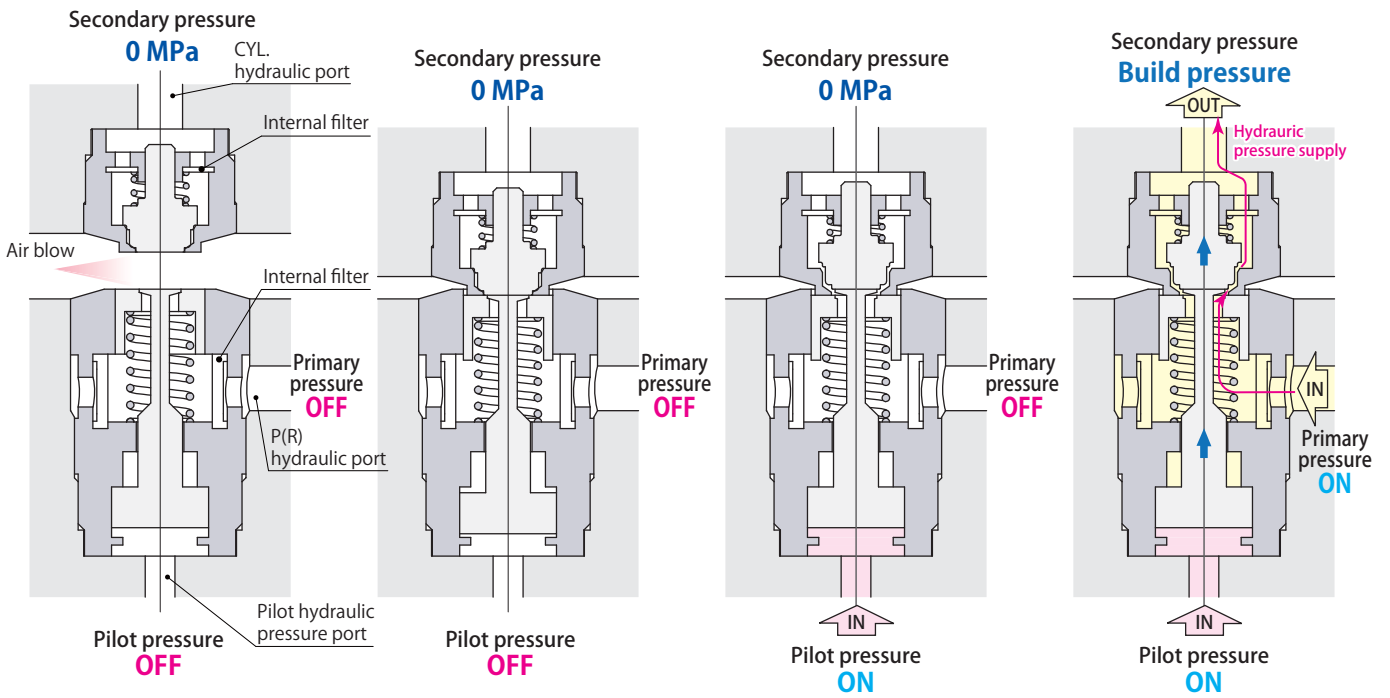

Do not supply primary and pilot pressure when coupler disconnected state.

Connect the couplers.

Supply pilot pressure to open the check valve.

Supply primary pressure after pilot pressure is supplied.

Clamp pressure release action

- ① Disconnected state
- ② Connecting
- ③ Clamp pressure release action-1

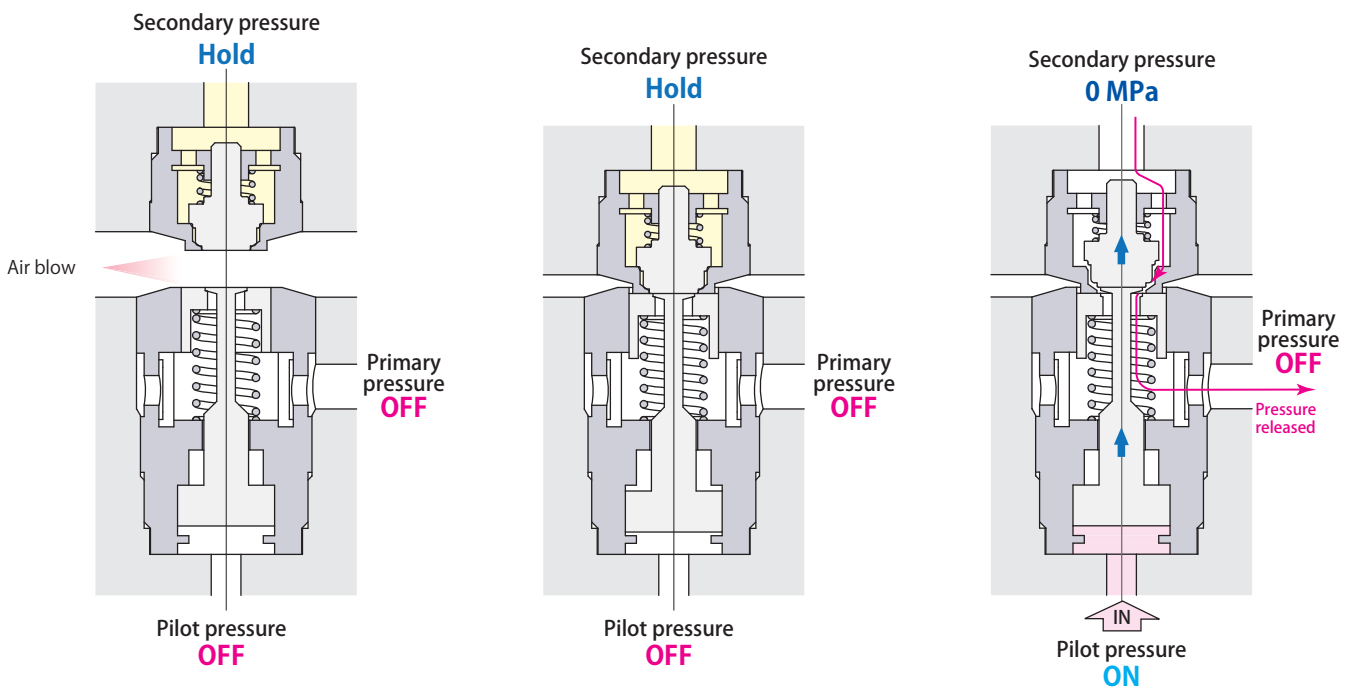

Do not supply primary and pilot pressure when coupler disconnected state.

Connect the couplers.

Supply pilot pressure after connection and release the clamp pressure.

Pilot coupler

WVP Oil

⑤ Pressure holding action-1

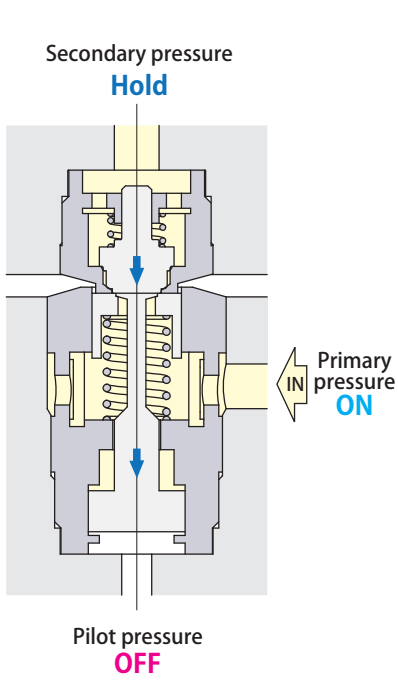

Stop supplying pilot pressure after secondary pressure is built up.

⑥ Pressure holding action-2

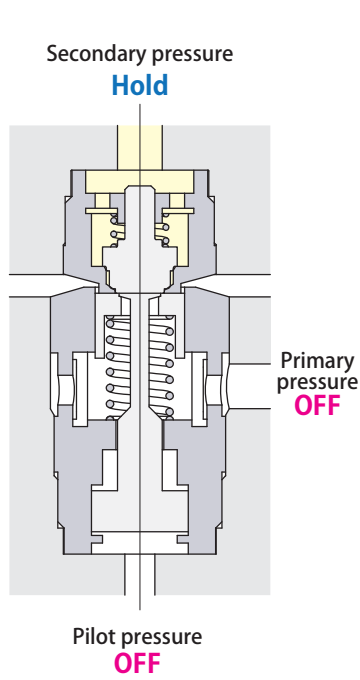

Stop supplying primary pressure after pilot pressure is supplied.

⑦ Coupler disconnecting action

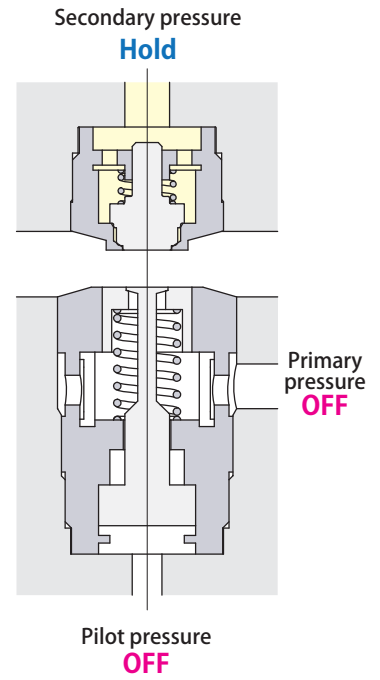

Clamp pressure is kept even after coupler is disconnected.

④ Clamp pressure release action-2

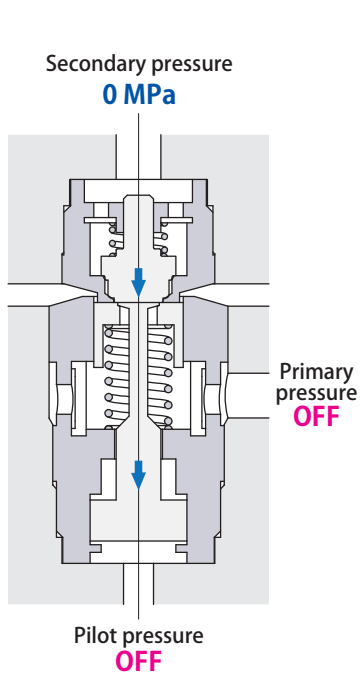

Stop supplying pilot pressure after clamp pressure is released.

⑤ Coupler disconnecting action

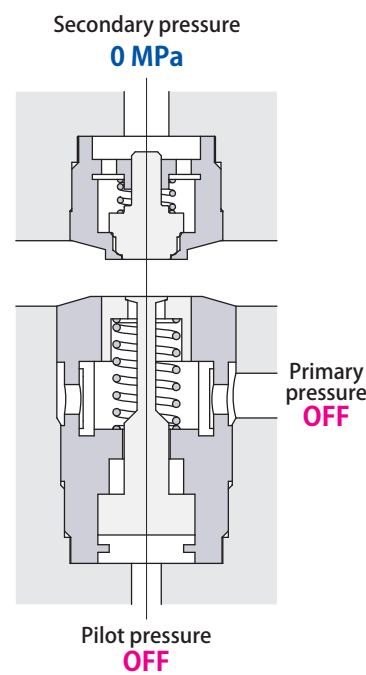

Disconnect couplers.

Caution in use

- Install the stopper to have the dimension $51.5_{-0.5}^0$ (See diagram on the below).
Observe allowable eccentricity and inclination value when installing the guide (Refer to **page →94**).

- Prepare a spacer block (by customer) separately when coupler is used with a pallet clamp.

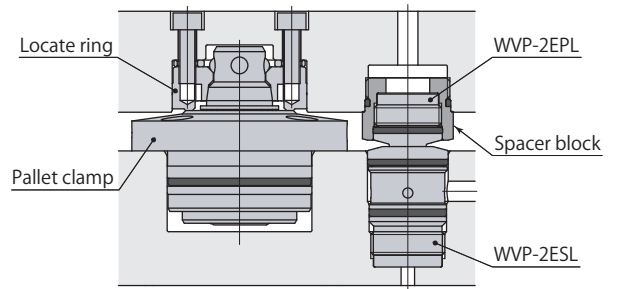
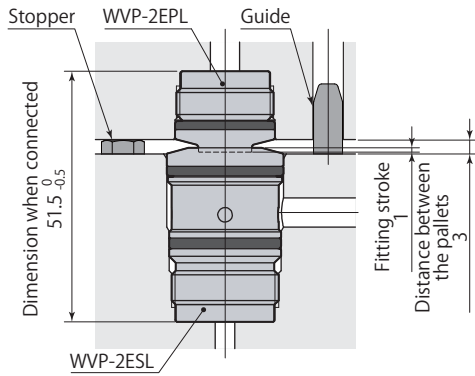

Hydraulic circuit diagram for double acting clamp

Hydraulic circuit diagram for single acting clamp

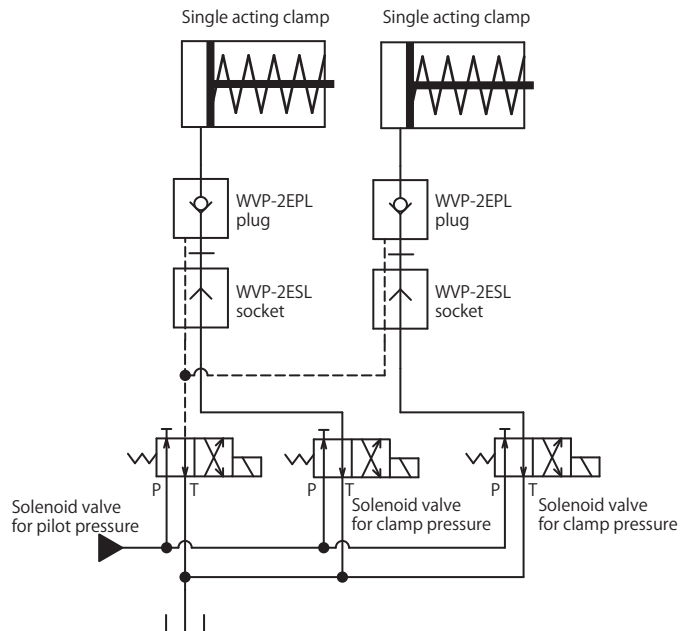
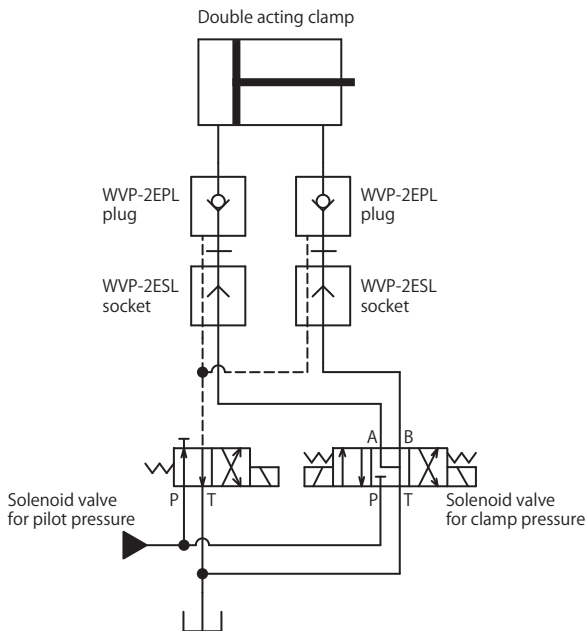

- 3 position, center tank-port solenoid valve should be used for clamp pressure circuit to avoid back pressure. A solenoid valve which switches to Tank port connection except supplying pressure to the circuit should be used.

- A solenoid valve which switches to Tank port connection except supplying pressure to the circuit should be used to avoid back pressure.