



Control unit model **HCS D-H□U**

This is a hydraulic control unit that is air driven and solenoidal operated, combining non-leak valve with non-leak feature (zero oil leaks), which is essential for hydraulic clamps, and Pascal pump. Since two hydraulic circuits can be operated and controlled alternately, it is best suited hydraulic pressure source for double acting clamps.

Pascal pump stops pumping once circuit pressure has been attained and retains the pressure. Furthermore, since there is hardly any temperature fluctuation of working fluid, there is no need for any auxiliary pressure equipment.

HCS D-H□U is made to order.

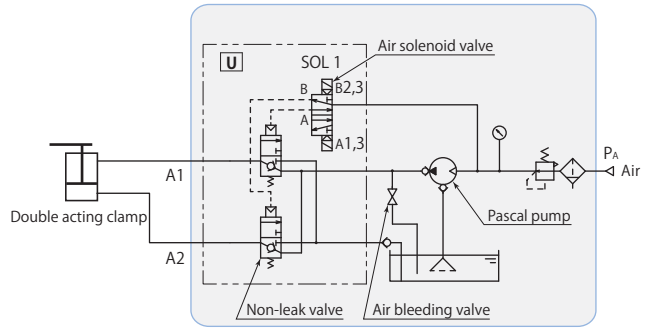

Model	HCS D-H4U	HCS D-H5U
Pascal pump	X6312U-D	X6316U-D
Control voltage*1	DC24V	
Discharge oil pressure*2	MPa 3.6–10.8	2.25–6.75
Set air pressure	MPa 0.2–0.5	
Unloaded oil discharge amount	L/min Refer to page → 205 for performance diagram.	
Tank capacity*3	L H.L. 3.5	L.L. 1.5
Operating temperature °C	0–50	
Fluid used	General mineral based hydraulic oil (ISO-VG32 equivalent)	
Mass	kg 20	

- \*1: Ask us if the control voltage is different.
- \*2: Ask for consultation on specifications that exceed discharge oil pressure range.
- \*3: Oil level in the tank should be always between H.L. and L.L. of the gauge.

**Dimensions**

**HCS D-H□U Double acting circuit control unit**

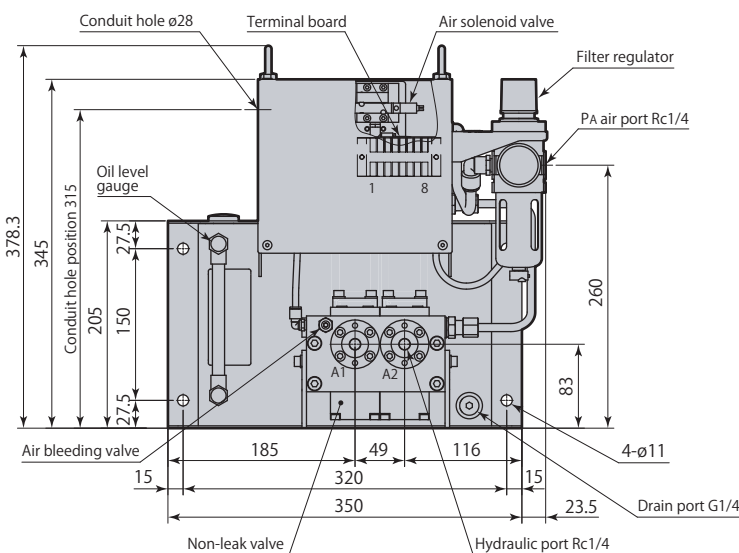
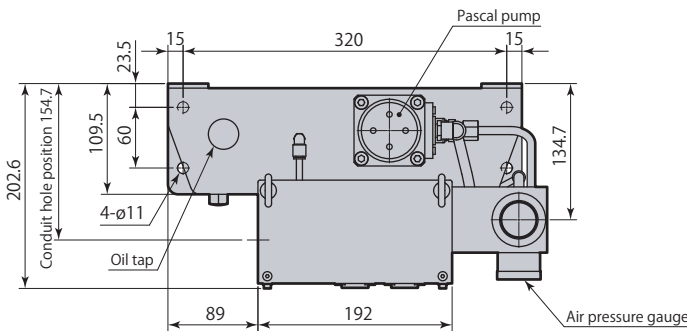

**Wiring Diagram**

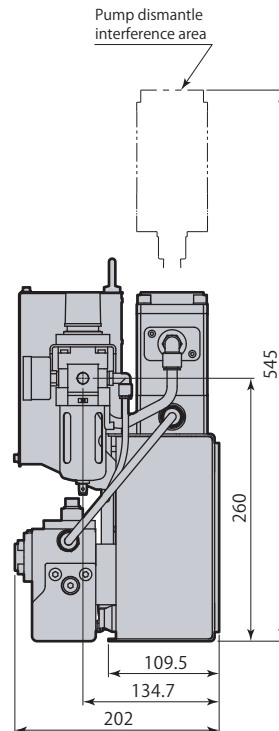
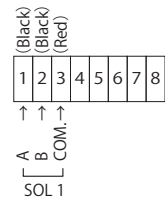

Control unit

HCS Solenoid operated



Control unit model **HCS-D-H□A**

This is a hydraulic control unit that is air driven and solenoidal operated, combining non-leak valve with non-leak feature (zero oil leaks), which is essential for hydraulic clamps, and Pascal pump.

Pascal pump stops pumping once circuit pressure has been attained and retains the pressure. Furthermore, since there is hardly any temperature fluctuation of working fluid, there is no need for any auxiliary pressure equipment.

HCS-D-H□A is made to order.

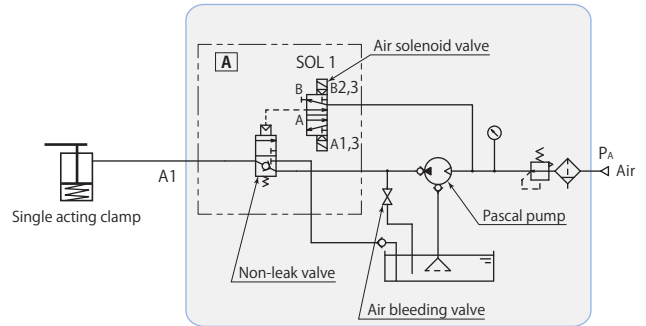

Model	HCS-D-H4A	HCS-D-H5A
Pascal pump	X6312U-D	X6316U-D
Control voltage*1	DC24V	
Discharge oil pressure*2	MPa 3.6–10.8	2.25–6.75
Set air pressure	MPa 0.2–0.5	
Unloaded oil discharge amount	L/min Refer to <b>page → 205</b> for performance diagram.	
Tank capacity*3	L H.L. 3.5	L.L. 1.5
Operating temperature °C	0–50	
Fluid used	General mineral based hydraulic oil (ISO-VG32 equivalent)	
Mass	kg 17	

- \*1: Ask us if the control voltage is different.
- \*2: Ask for consultation on specifications that exceed discharge oil pressure range.
- \*3: Oil level in the tank should be always between H.L. and L.L. of the gauge.

**Dimensions**

**HCS-D-H□A Single acting circuit control unit**

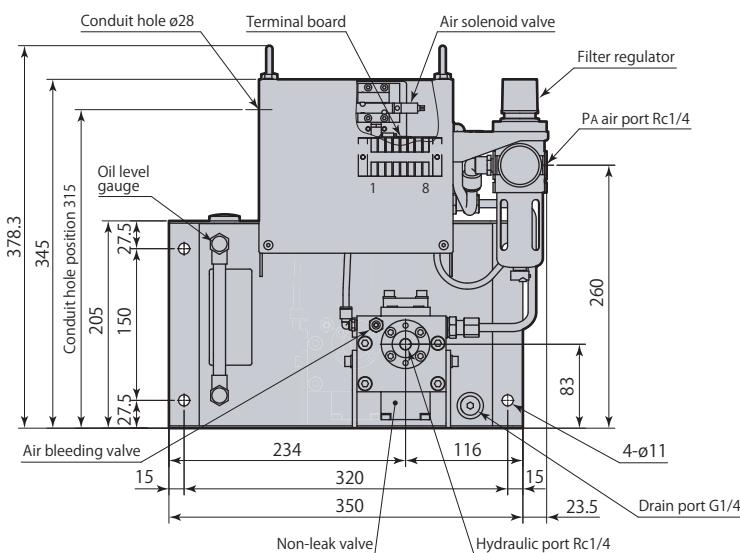
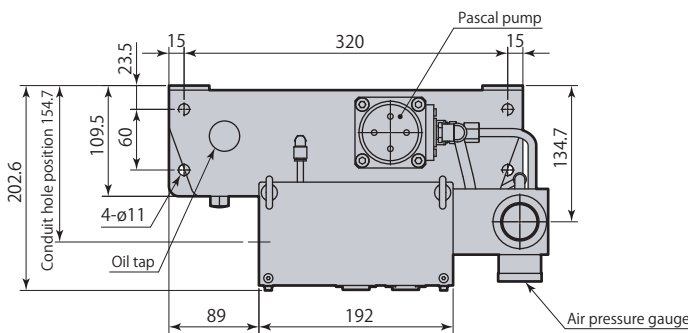

**Wiring Diagram**

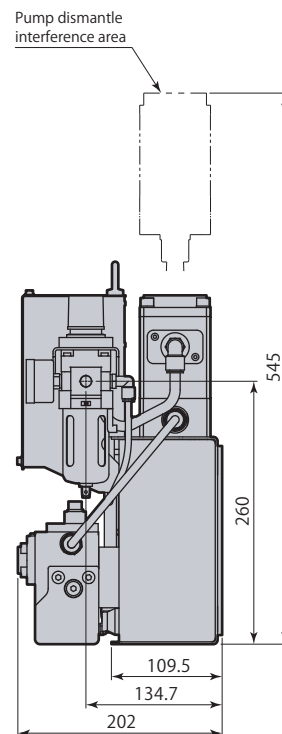
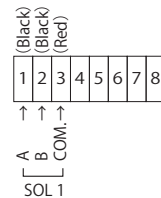

Control unit  
HCS  
Solenoid operated