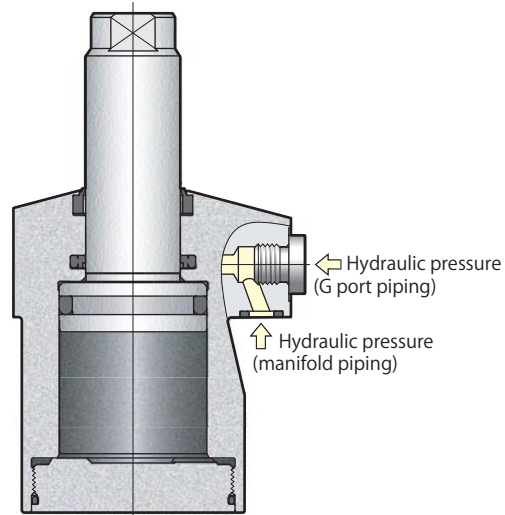
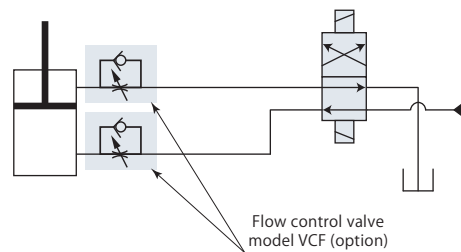

## Standard model

model CNA□-□□

Hydraulic circuit diagram

For flow control valve, we recommend the meter-in control. If meter-out control is used, due to the area difference, it will cause back pressure and become high pressure. This can lead to malfunction of the system. Please be aware when designing the circuit.

Specifications	page → 75
Piping	page → 75
Standard	page → 76
Dual rod	page → 84
Air sensor	page → 86

Specifications

Size	Stroke	Rod tip section shapes	Variation code
<b>02</b>	<b>10 15 20 30 40 50 (60) (70)</b>		(Nil) : Standard
<b>04</b>	<b>10 15 20 30 40 50 60 70</b>	<b>T</b> : Female thread rod	<b>E</b> : Dual rod
<b>06</b>	<b>10 15 20 30 40 50 60 70 (80) (90)</b>	<b>P</b> : Pin rod	<b>A1</b> : Air sensor Detection 1mm before push end
<b>10</b>	<b>10 20 30 40 50 60 70 80 (90) (100)</b>	<b>M</b> : Male thread rod	<b>A3</b> : Air sensor Detection 3mm before push end
<b>16</b>	<b>10 20 30 40 50 60 70 80 (90) (100)</b>		<b>A5</b> : Air sensor Detection 5mm before push end
<b>25</b>	<b>20 30 40 50 60 70 80 90 (100) (110)</b>		

■ indicates made to order. Dual rod, air sensor model for the stroke with ( ) are unavailable.

Model			CNA02	CNA04	CNA06	CNA10	CNA16	CNA25
Cylinder force (hydraulic pressure 7MPa)	Push	kN	3.4	4.9	6.7	10.6	17.2	26.9
	Pull	kN	2.0	3.2	4.0	7.2	12.3	20.0
Cylinder force calculation formula*1	Push		$F=0.49 \times P$	$F=0.71 \times P$	$F=0.96 \times P$	$F=1.52 \times P$	$F=2.46 \times P$	$F=3.85 \times P$
	Pull		$F=0.29 \times P$	$F=0.45 \times P$	$F=0.57 \times P$	$F=1.03 \times P$	$F=1.76 \times P$	$F=2.86 \times P$
Cylinder inner diameter		mm	25	30	35	44	56	70
Rod diameter		mm	16	18	22.4	25	30	35.5
Effective area	Push	cm <sup>2</sup>	4.9	7.1	9.6	15.2	24.6	38.5
	Pull	cm <sup>2</sup>	2.9	4.5	5.7	10.3	17.6	28.6
Max. oil flow rate		L/min	1.0	1.6	2.1	5.0	8.4	10.5
Recommended tightening torque of mounting screws*2		N·m	7	7	12	29	57	77

- Pressure range : 1–7 MPa
  - Proof pressure : 10.5 MPa
  - Operating temperature : 0–70 °C
  - Fluid used : General mineral based hydraulic oil (ISO-VG32 equivalent)
  - Seals are resistant to chlorine-based cutting fluid. (not thermal resistant specification)
- \*1 : F=Cylinder force (kN), P=Hydraulic pressure (MPa)    \*2 : ISO R898 class 12.9

Manifold piping and G port piping are available.

Manifold piping

When choosing manifold piping, a flow control valve (model VCF) and an air bleeding valve (model VCE) are mountable on the G ports of the cylinder.

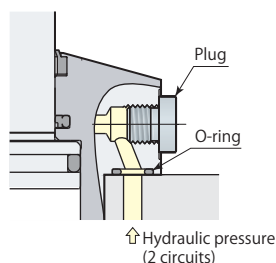

G port piping

Remove plugs when choosing G port piping. (O-ring must be used.) Refer to **page → 150** for details on G port piping flareless fitting. The flow control valve and the air bleeding valve should be installed in the middle of oil path.

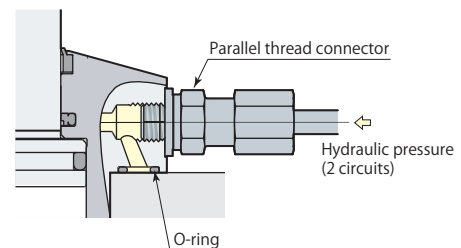

Dimensions

(Female thread rod)

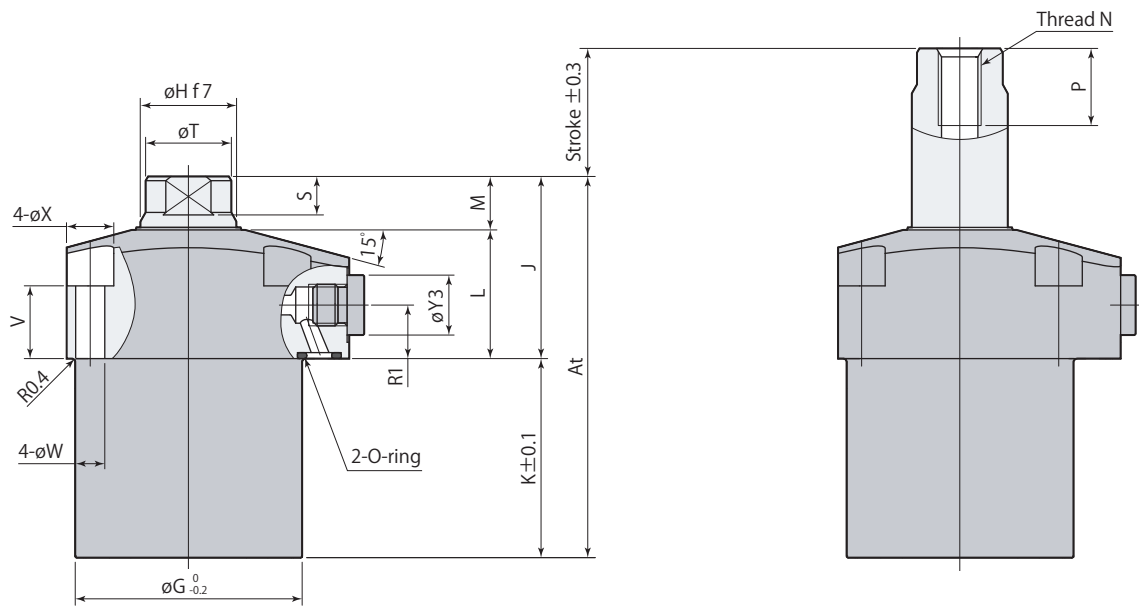
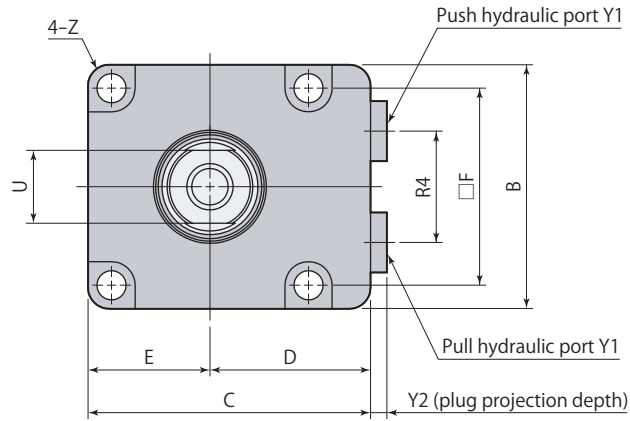

Pull end

Push end

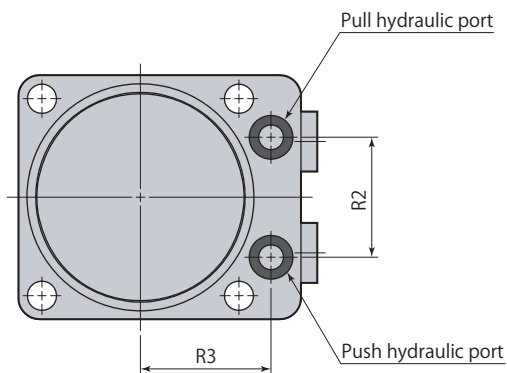

- Mounting screws are not included.
- Refer to **pages →84–89** for specifications of dual rod and air sensor models.

							mm
Model	CNA02-□T	CNA04-□T	CNA06-□T	CNA10-□T	CNA16-□T	CNA25-□T	
B	45	50	57	70	86	108	
C	55	60	66	82	96	120	
D	32.5	35	37.5	47	53	66	
E	22.5	25	28.5	35	43	54	
F	35	40	46	56	68	88	
øG	39	47	53	63	78	100	
øH	16 <sup>-0.016 -0.034</sup>	18 <sup>-0.016 -0.034</sup>	22.4 <sup>-0.020 -0.041</sup>	25 <sup>-0.020 -0.041</sup>	30 <sup>-0.020 -0.041</sup>	35.5 <sup>-0.025 -0.050</sup>	
J	38	39.5	42.5	51	57	65.5	
L	27.5	28	30	37.5	41.5	48.5	
M	10.5	11.5	12.5	13.5	15.5	17	
N	M8×1.25	M8×1.25	M10×1.5	M12×1.75	M16×2	M20×2.5	
P	14	14	18	21	27	33	
R1	12.5	12.5	12.5	14	14	21	
R2	22	24	28	36	45	50	
R3	25	28	30.5	36	42	57	
R4	20	22	26	30	38	50	
S (width across flats height)	7	8	9	10	12	14	
øT	14±0.2	16±0.2	20±0.2	23±0.2	28±0.2	33.5±0.3	
U (width across flats)	12	14	17	19	24	30	
V	18	17	17	20	20	20	
øW	5.5	5.5	6.8	9	11	14	
øX	9.5	9.5	11	14	17.5	20	
Y1	G1/8	G1/8	G1/8	G1/4	G1/4	G3/8	
Y2	3.8	3.8	3.8	4.8	4.8	4.8	
øY3	14	14	14	19	19	22	
Z	R3	R5	R5	R6	R7	R10	
O-ring (fluorocarbon hardness Hs90)	P7	P7	P7	P8	P8	P10	
Flow control valve*	Meter-in	VCF01	VCF01	VCF01	VCF02	VCF02	VCF03
	Meter-out	VCF01-O	VCF01-O	VCF01-O	VCF02-O	VCF02-O	VCF03-O
Air bleeding valve*	VCE01	VCE01	VCE01	VCE02	VCE02	VCE03	

\*: Select the right model of VCF and VCE according to the size of the cylinder.

Refer to each page for the details of options. ● Flow control valve **page →100** ● Air bleeding valve **page →102**

● CNA□-□T (Female thread rod) size 02, 04, 16, 25 or more than 60 mm stroke are made to order.

CNA02-Stroke			10	15	20	30	40	50	60	70
Cylinder capacity	Push	cm <sup>3</sup>	4.9	7.4	9.8	14.7	19.6	24.5	29.4	34.3
	Pull	cm <sup>3</sup>	2.9	4.3	5.8	8.7	11.6	14.5	17.4	20.3
	At	mm	66		81		101		121	
	K	mm	28		43		63		83	
	Mass	kg	0.7		0.8		1.0	0.9	1.1	

● Stroke 10, 20, 40, and 60 use spacers.

CNA04-Stroke			10	15	20	30	40	50	60	70	
Cylinder capacity	Push	cm <sup>3</sup>	7.1	10.6	14.1	21.2	28.3	35.3	42.4	49.5	
	Pull	cm <sup>3</sup>	4.5	6.8	9.0	13.6	18.1	22.6	27.1	31.7	
	At	mm	70.5			85.5		105.5		125.5	
	K	mm	31		46		66		86		
	Mass	kg	0.9		1.1		1.3		1.5		

● Stroke 10, 20, 40, and 60 use spacers.

CNA06-Stroke			10	15	20	30	40	50	60	70	80	90
Cylinder capacity	Push	cm <sup>3</sup>	9.6	14.4	19.2	28.9	38.5	48.1	57.7	67.3	77.0	86.6
	Pull	cm <sup>3</sup>	5.7	8.5	11.4	17.0	22.7	28.4	34.1	39.8	45.4	51.1
	At	mm	74		89		109		129		149	
	K	mm	31.5		46.5		66.5		86.5		106.5	
	Mass	kg	1.2		1.4		1.7		1.9		2.2	

● Stroke 10, 20, 40, 60 and 80 use spacers.

CNA10-Stroke			10	20	30	40	50	60	70	80	90	100
Cylinder capacity	Push	cm <sup>3</sup>	15.2	30.4	45.6	60.8	76.0	91.2	106.4	121.6	136.8	152.1
	Pull	cm <sup>3</sup>	10.3	20.6	30.9	41.2	51.5	61.8	72.1	82.4	92.7	103.0
	At	mm	88.5		108.5		128.5		148.5		168.5	
	K	mm	37.5		57.5		77.5		97.5		117.5	
	Mass	kg	2.1		2.4		2.7		3.1		3.4	

● Stroke 10, 30, 50, 70 and 90 use spacers.

CNA16-Stroke			10	20	30	40	50	60	70	80	90	100
Cylinder capacity	Push	cm <sup>3</sup>	24.6	49.3	73.9	98.5	123.2	147.8	172.4	197.0	221.7	246.3
	Pull	cm <sup>3</sup>	17.6	35.1	52.7	70.2	87.8	105.4	122.9	140.5	158.1	175.6
	At	mm	96		116		136		156		176	
	K	mm	39		59		79		99		119	
	Mass	kg	3.3		3.8		4.3		4.7		5.2	

● Stroke 10, 30, 50, 70 and 90 use spacers.

CNA25-Stroke			20	30	40	50	60	70	80	90	100	110
Cylinder capacity	Push	cm <sup>3</sup>	77.0	115.5	153.9	192.4	230.9	269.4	307.9	346.4	384.8	423.3
	Pull	cm <sup>3</sup>	57.2	85.8	114.3	142.9	171.5	200.1	228.7	257.3	285.9	314.5
	At	mm	115.5		135.5		155.5		175.5		195.5	
	K	mm	50		70		90		110		130	
	Mass	kg	6.3		7.1		7.8		8.6		9.4	

● Stroke 20, 40, 60, 80 and 100 use spacers.

Mounting details

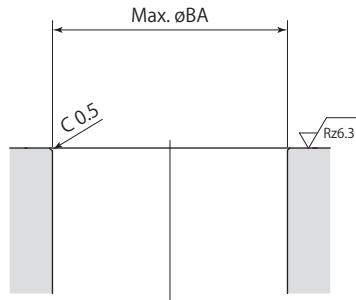
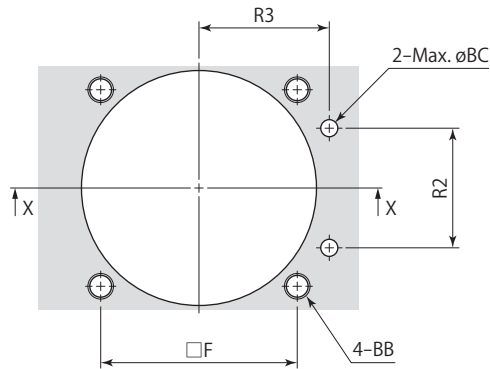

X-X

Rz: ISO4287(1997)

mm

Model	CNA02-□T	CNA04-□T	CNA06-□T	CNA10-□T	CNA16-□T	CNA25-□T
F	35	40	46	56	68	88
R2	22	24	28	36	45	50
R3	25	28	30.5	36	42	57
øBA	40	48	54	64	79	101
BB	M5	M5	M6	M8	M10	M12
øBC	4	4	4	6	6	8

Dimensions

(Pin rod)

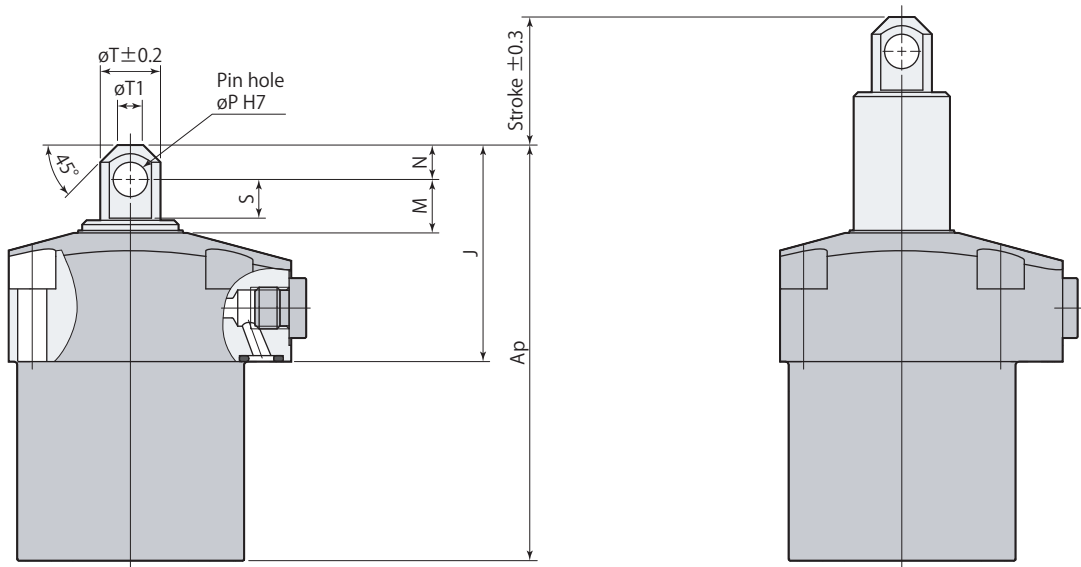
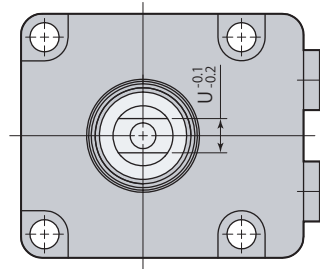

Pull end

Push end

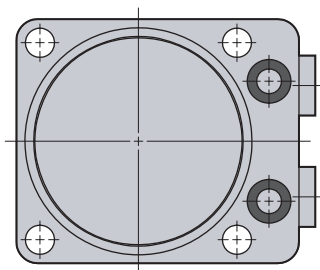

- Mounting screws are not included.
- Recommended material for pin: SCM435-H (HB269-331)
- Refer to **pages →76-79** for specifications and dimensions that are not shown in the diagram.
- Refer to **pages →84-89** for specifications of dual rod and air sensor models.

Push, pull cylinder

CNA-P Pin rod

Model	CNA02-□P	CNA04-□P	CNA06-□P	CNA10-□P	CNA16-□P	CNA25-□P
J	42.5	44.5	50.5	60	67	79.5
M	10	10.5	12.5	13.5	14.5	18
N	5	6	8	9	11	13
øP	6 <sup>+0.012</sup> <sub>0</sub>	6 <sup>+0.012</sup> <sub>0</sub>	8 <sup>+0.015</sup> <sub>0</sub>	10 <sup>+0.015</sup> <sub>0</sub>	12 <sup>+0.018</sup> <sub>0</sub>	14 <sup>+0.018</sup> <sub>0</sub>
S	6.5	7	9	10	10.8	14.5
øT	10	12	14	16	20	26
øT1	5	5	6	8	10	14
U	6	6	8	11	14	16

mm

● CNA□-□P (Pin rod) is made to order.

CNA02-Stroke		10	15	20	30	40	50	60	70
Ap	mm	70.5		85.5		105.5		125.5	
Mass	kg	0.7		0.8		1.0	0.9	1.1	

CNA04-Stroke		10	15	20	30	40	50	60	70
Ap	mm	75.5		90.5		110.5		130.5	
Mass	kg	0.9		1.1		1.3		1.5	

CNA06-Stroke		10	15	20	30	40	50	60	70	80	90
Ap	mm	82	97		117		137		157		
Mass	kg	1.2	1.4		1.7		1.9		2.2		

CNA10-Stroke		10	20	30	40	50	60	70	80	90	100
Ap	mm	97.5	117.5		137.5		157.5		177.5		
Mass	kg	2.1	2.4		2.7		3.1		3.4		

CNA16-Stroke		10	20	30	40	50	60	70	80	90	100
Ap	mm	106	126		146		166		186		
Mass	kg	3.3	3.8		4.3		4.7		5.2		

CNA25-Stroke		20	30	40	50	60	70	80	90	100	110
Ap	mm	129.5	149.5		169.5		189.5		209.5		
Mass	kg	6.3	7.1		7.9		8.6		9.5	9.4	



Dimensions

(Male thread rod)

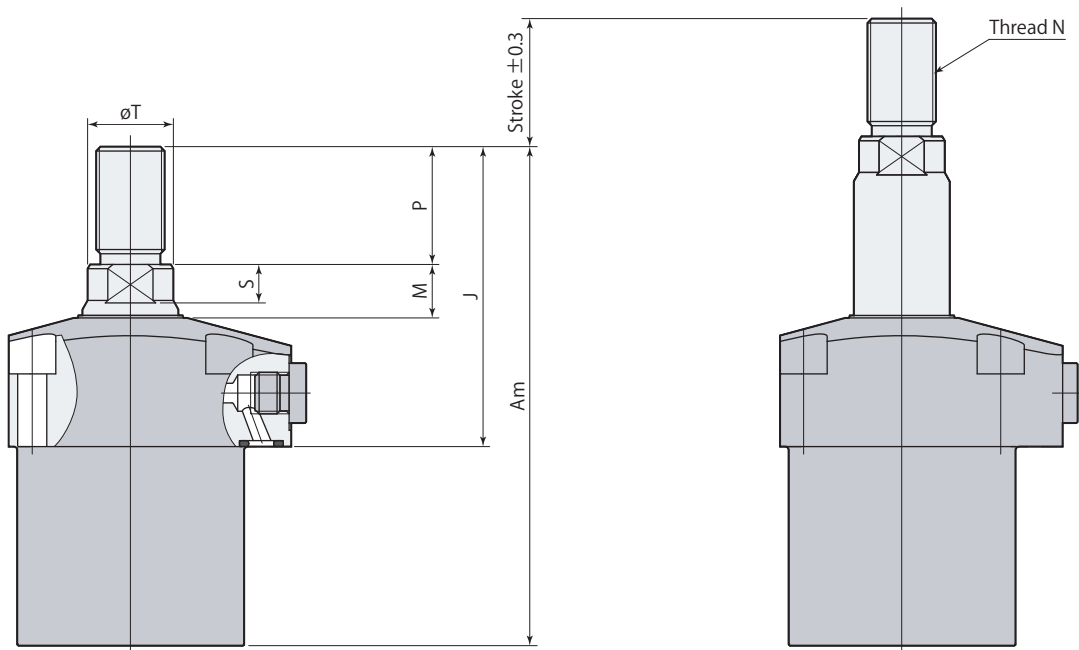
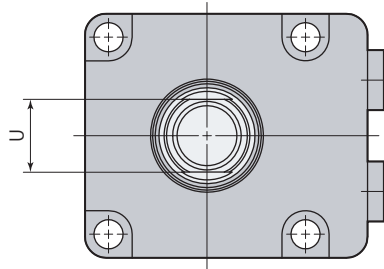
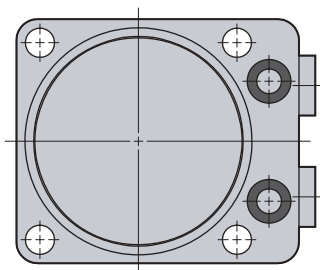
Pull endPush end

- Mounting screws are not included.
- Refer to **pages →76–79** for specifications and dimensions that are not shown in the diagram.
- Refer to **pages →84–89** for specifications of dual rod and air sensor models.

Model	CNA02-□M	CNA04-□M	CNA06-□M	CNA10-□M	CNA16-□M	CNA25-□M
J	58	64.5	70	81	92	110.5
M	10.5	11.5	12.5	13.5	15.5	17
N	M12×1.25	M14×1.5	M16×1.5	M20×1.5	M24×1.5	M30×1.5
P	20	25	27.5	30	35	45
S (width across flats height)	7	8	9	10	12	14
øT	14±0.2	16±0.2	20±0.2	23±0.2	28±0.2	33.5±0.3
U (width across flats)	12	14	17	19	24	30

mm

● CNA□-□M (Male thread rod) is made to order.

CNA02-Stroke		10	15	20	30	40	50	60	70
Am	mm	86		101		121		141	
Mass	kg	0.7		0.8		1.0		1.1	

CNA04-Stroke		10	15	20	30	40	50	60	70
Am	mm	95.5		110.5		130.5		150.5	
Mass	kg	1.0		1.1		1.3		1.5	

CNA06-Stroke		10	15	20	30	40	50	60	70	80	90
Am	mm	101.5		116.5		136.5		156.5		176.5	
Mass	kg	1.3		1.5		1.7		2.0		2.3	

CNA10-Stroke		10	20	30	40	50	60	70	80	90	100
Am	mm	118.5		138.5		158.5		178.5		198.5	
Mass	kg	2.2		2.5		2.8		3.2		3.5	

CNA16-Stroke		10	20	30	40	50	60	70	80	90	100
Am	mm	131		151		171		191		211	
Mass	kg	3.5		4.0		4.4		4.9		5.4	

CNA25-Stroke		20	30	40	50	60	70	80	90	100	110
Am	mm	160.5		180.5		200.5		220.5		240.5	
Mass	kg	6.6		7.4		8.2		9.0		9.7	

Specifications

Model			CNA02-□□E	CNA04-□□E	CNA06-□□E	CNA10-□□E	CNA16-□□E	CNA25-□□E
Cylinder force (hydraulic pressure 7MPa)	Push	kN	3.1	4.4	6.2	9.9	16.4	25.5
	Pull	kN	2.0	3.2	4.0	7.2	12.3	20.0
Cylinder inner diameter		mm	25	30	35	44	56	70
Rod diameter		mm	16	18	22.4	25	30	35.5
Sensor rod diameter		mm	8	10	10	12	12	16
Effective area	Push	cm <sup>2</sup>	4.4	6.3	8.8	14.1	23.5	36.5
	Pull	cm <sup>2</sup>	2.9	4.5	5.7	10.3	17.6	28.6

● CNA□-□□E (Dual rod) is made to order.

Usage example

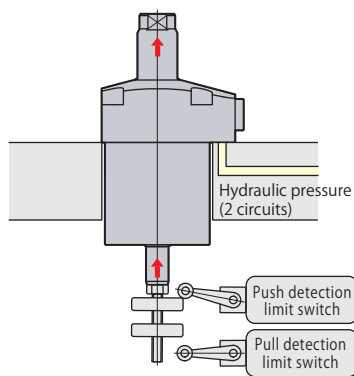

Dimensions

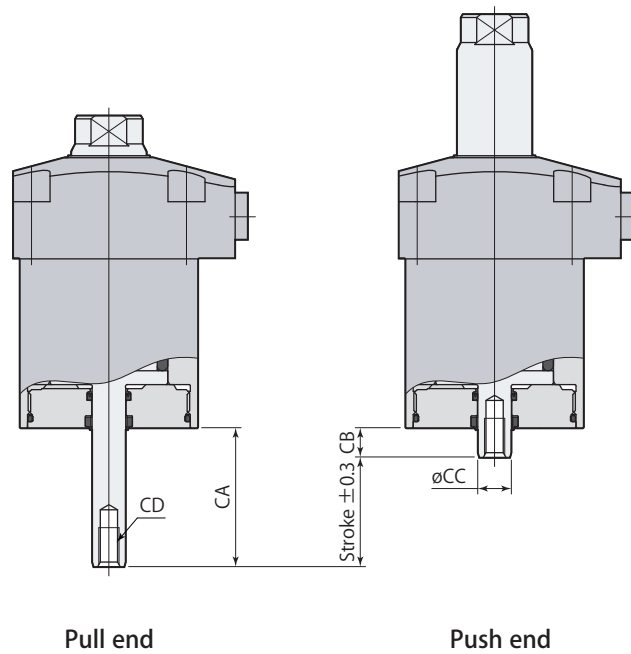

- This diagram depicts shape of female thread rod.
- Mounting screws are not included.
- Refer to specifications (page →75), dimensions (pages →76–83) for specifications and dimensions that are not shown in the diagram.

CNA02-Stroke			10	15	20	30	40	50
Cylinder capacity	Push	cm <sup>3</sup>	4.4	6.6	8.8	13.2	17.6	22.0
	Pull	cm <sup>3</sup>	2.9	4.3	5.8	8.7	11.6	14.5
CA		mm	23	23	38	38	58	58
CB		mm	13	8	18	8	18	8
øCC		mm	8					
CD		mm	M5×0.8 depth 8					
Mass	TE : Female thread rod	kg	0.7	0.7	0.8	0.8	0.9	0.9
	PE : Pin rod	kg	0.7	0.7	0.8	0.8	0.9	0.9
	ME : Male thread rod	kg	0.7	0.7	0.8	0.8	1.0	1.0

● Stroke 10, 20, and 40 use spacers.

CNA04-Stroke			10	15	20	30	40	50	60	70
Cylinder capacity	Push	cm <sup>3</sup>	6.3	9.4	12.6	18.8	25.1	31.4	37.7	44.0
	Pull	cm <sup>3</sup>	4.5	6.8	9.0	13.6	18.1	22.6	27.1	31.7
CA		mm	23	23	38	38	58	58	78	78
CB		mm	13	8	18	8	18	8	18	8
øCC		mm	10							
CD		mm	M6×1 depth 11							
Mass	TE : Female thread rod	kg	0.9		1.1		1.3		1.5	
	PE : Pin rod	kg	0.9		1.1		1.3		1.5	
	ME : Male thread rod	kg	0.9		1.1		1.3		1.5	

● Stroke 10, 20, 40, and 60 use spacers.

CNA06-Stroke			10	15	20	30	40	50	60	70
Cylinder capacity	Push	cm <sup>3</sup>	8.8	13.3	17.7	26.5	35.3	44.2	53.0	61.9
	Pull	cm <sup>3</sup>	5.7	8.5	11.4	17.0	22.7	28.4	34.1	39.8
CA		mm	23	23	38	38	58	58	78	78
CB		mm	13	8	18	8	18	8	18	8
øCC		mm	10							
CD		mm	M6×1 depth 11							
Mass	TE : Female thread rod	kg	1.2	1.2	1.4	1.4	1.7	1.7	1.9	1.9
	PE : Pin rod	kg	1.2	1.2	1.4	1.4	1.7	1.7	1.9	1.9
	ME : Male thread rod	kg	1.3	1.3	1.5	1.4	1.7	1.7	2.0	2.0

● Stroke 10, 20, 40, and 60 use spacers.

CNA10-Stroke			10	20	30	40	50	60	70	80
Cylinder capacity	Push	cm <sup>3</sup>	14.1	28.1	42.2	56.3	70.4	84.4	98.5	112.6
	Pull	cm <sup>3</sup>	10.3	20.6	30.9	41.2	51.5	61.8	72.1	82.4
CA		mm	28	28	48	48	68	68	88	88
CB		mm	18	8	18	8	18	8	18	8
øCC		mm	12							
CD		mm	M8×1.25 depth 15							
Mass	TE : Female thread rod	kg	2.2	2.1	2.5	2.5	2.8	2.8	3.2	3.1
	PE : Pin rod	kg	2.2	2.1	2.5	2.5	2.8	2.8	3.2	3.1
	ME : Male thread rod	kg	2.2	2.2	2.6	2.5	2.9	2.9	3.2	3.2

● Stroke 10, 30, 50 and 70 use spacers.

CNA16-Stroke			10	20	30	40	50	60	70	80
Cylinder capacity	Push	cm <sup>3</sup>	23.5	47.0	70.5	94.0	117.5	141.0	164.5	188.0
	Pull	cm <sup>3</sup>	17.6	35.1	52.7	70.2	87.8	105.4	122.9	140.5
CA		mm	28	28	48	48	68	68	88	88
CB		mm	18	8	18	8	18	8	18	8
øCC		mm	12							
CD		mm	M8×1.25 depth 15							
Mass	TE : Female thread rod	kg	3.4	3.3	3.9	3.8	4.3	4.3	4.8	4.8
	PE : Pin rod	kg	3.4	3.3	3.9	3.8	4.4	4.3	4.9	4.8
	ME : Male thread rod	kg	3.5	3.4	3.9	3.9	4.4	4.4	4.9	4.9

● Stroke 10, 30, 50 and 70 use spacers.

CNA25-Stroke			20	30	40	50	60	70	80	90
Cylinder capacity	Push	cm <sup>3</sup>	72.9	109.4	145.9	182.4	218.8	255.3	291.8	328.3
	Pull	cm <sup>3</sup>	57.2	85.8	114.3	142.9	171.5	200.1	228.7	257.3
CA		mm	38	38	58	58	78	78	98	98
CB		mm	18	8	18	8	18	8	18	8
øCC		mm	16							
CD		mm	M10×1.5 depth 18							
Mass	TE : Female thread rod	kg	6.3	6.2	7.2	7.0	7.9	7.8	8.7	8.7
	PE : Pin rod	kg	6.4	6.3	7.2	7.1	8.0	7.9	8.8	8.7
	ME : Male thread rod	kg	6.6	6.6	7.4	7.4	8.3	8.2	9.1	9.0

● Stroke 20, 40, 60, and 80 use spacers.

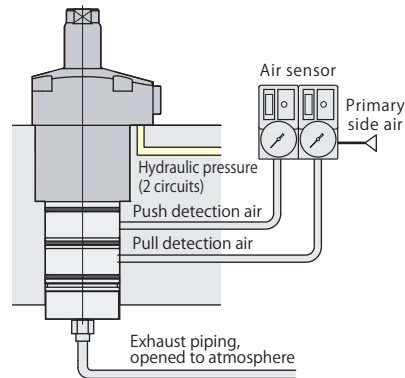
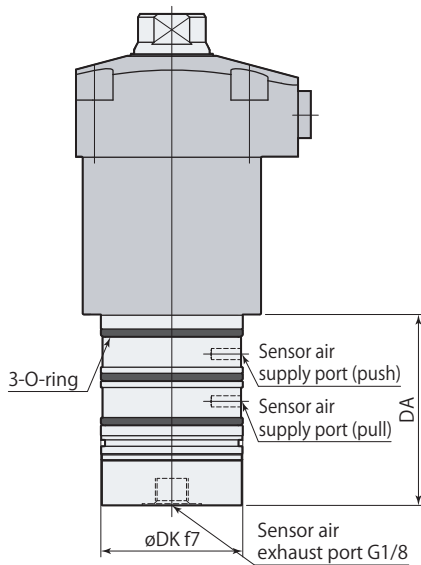
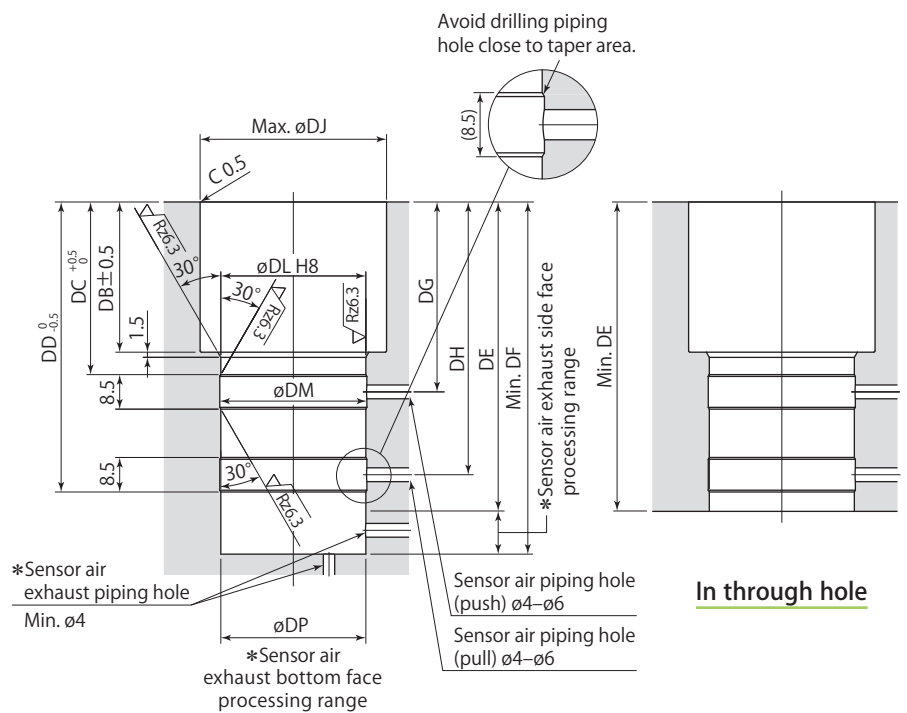
Usage exampleDimensionsMounting detailsIn blind hole

Rz: ISO4287(1997)

- This diagram depicts shape of female thread rod.
- Exhaust port must be opened to atmosphere. If sensor is embedded in a jig, prepare an exhaust piping hole. Furthermore, provide the piping if there is a risk of coolant or metal chips intrusion. Use one-touch fittings manufactured by SMC for G port piping. (See SMC catalog for the details of the fitting.)
- Apply an appropriate amount of grease to the chamfer and the bore when mounting. Excessive grease may be a blockage in the air passage, causing malfunction of the sensor.
- The  $30^\circ$  taper machining must be provided to avoid the damage of the O-ring. Ensure that there are no interference on taper area when drilling the hole for sensor air.
- Refer to specifications (**page →84**), dimensions (**pages →76–83**) for specifications and dimensions that are not shown in the diagram.
- CNA□-□□A (Air sensor) is made to order.

CNA02-Stroke		10	15	20	30	40	50
DA	mm	41		56		76	
DB	mm	29		44		64	
DC	mm	35.5		50.5		70.5	
DD	mm	58		73		93	
DE	mm	64.5		79.5		99.5	
DF	mm	73		103		143	
DG	mm	40		55		75	
DH	mm	53.5		68.5		88.5	
øDJ	mm			40			
øDK	mm			38 <sup>-0.025</sup> <sub>-0.050</sub>			
øDL	mm			38 <sup>+0.039</sup> <sub>0</sub>			
øDM	mm			38.6			
øDP	mm			38			
O-ring		AS568-028 (fluorocarbon hardness Hs70)					
Mass	TA :Female thread rod	kg	0.8		1.0		1.2
	PA :Pin rod	kg	0.8		1.0		1.2
	MA :Male thread rod	kg	0.9		1.0		1.2

CNA04-Stroke		10	15	20	30	40	50	60	70	
DA	mm	43.5		56.5		76.5		96.5		
DB	mm	32		47		67		87		
DC	mm	38.5		53.5		73.5		93.5		
DD	mm	61		76		96		116		
DE	mm	67.5		82.5		102.5		122.5		
DF	mm	78.5		106.5		146.5		186.5		
DG	mm	43		58		78		98		
DH	mm	56.5		71.5		91.5		111.5		
øDJ	mm			48						
øDK	mm			42 <sup>-0.025</sup> <sub>-0.050</sub>						
øDL	mm			42 <sup>+0.039</sup> <sub>0</sub>						
øDM	mm			42.6						
øDP	mm			42						
O-ring		AS568-029 (fluorocarbon hardness Hs70)								
Mass	TA :Female thread rod	kg	1.1	1.1	1.4	1.3	1.6	1.6	1.9	1.9
	PA :Pin rod	kg	1.1	1.1	1.4	1.3	1.6	1.6	1.9	1.9
	MA :Male thread rod	kg	1.2	1.2	1.4	1.4	1.7	1.6	1.9	1.9

CNA06-Stroke		10	15	20	30	40	50	60	70	
DA	mm	43.5		56.5		76.5		96.5		
DB	mm	32.5		47.5		67.5		87.5		
DC	mm	39		54		74		94		
DD	mm	61.5		76.5		96.5		116.5		
DE	mm	68		83		103		123		
DF	mm	79		107		147		187		
DG	mm	43.5		58.5		78.5		98.5		
DH	mm	57		72		92		112		
øDJ	mm			54						
øDK	mm			42 <sup>-0.025</sup> <sub>-0.050</sub>						
øDL	mm			42 <sup>+0.039</sup> <sub>0</sub>						
øDM	mm			42.6						
øDP	mm			42						
O-ring		AS568-029 (fluorocarbon hardness Hs70)								
Mass	TA :Female thread rod	kg	1.4	1.3	1.6	1.6	1.9	1.9	2.2	2.2
	PA :Pin rod	kg	1.4	1.3	1.6	1.6	1.9	1.9	2.2	2.2
	MA :Male thread rod	kg	1.4	1.4	1.7	1.6	2.0	2.0	2.3	2.3

CNA10-Stroke		10	20	30	40	50	60	70	80	
DA	mm	47.5		67.5		87.5		107.5		
DB	mm	38.5		58.5		78.5		98.5		
DC	mm	45		65		85		105		
DD	mm	67.5		87.5		107.5		127.5		
DE	mm	74		94		114		134		
DF	mm	89		129		169		209		
DG	mm	49.5		69.5		89.5		109.5		
DH	mm	63		83		103		123		
øDJ	mm	64								
øDK	mm	45 <sup>-0.025</sup> <sub>-0.050</sub>								
øDL	mm	45 <sup>+0.039</sup> <sub>0</sub>								
øDM	mm	45.6								
øDP	mm	45								
O-ring		AS568-030 (fluorocarbon hardness Hs70)								
Mass	TA :Female thread rod	kg	2.6	2.5	3.0	2.9	3.4	3.3	3.8	3.7
	PA :Pin rod	kg	2.6	2.5	3.0	2.9	3.4	3.3	3.8	3.7
	MA :Male thread rod	kg	2.6	2.6	3.1	3.0	3.5	3.4	3.9	3.8

CNA16-Stroke		10	20	30	40	50	60	70	80	
DA	mm	47.5		67.5		87.5		107.5		
DB	mm	40		60		80		100		
DC	mm	46.5		66.5		86.5		106.5		
DD	mm	69		89		109		129		
DE	mm	75.5		95.5		115.5		135.5		
DF	mm	90.5		130.5		170.5		210.5		
DG	mm	51		71		91		111		
DH	mm	64.5		84.5		104.5		124.5		
øDJ	mm	79								
øDK	mm	45 <sup>-0.025</sup> <sub>-0.050</sub>								
øDL	mm	45 <sup>+0.039</sup> <sub>0</sub>								
øDM	mm	45.6								
øDP	mm	45								
O-ring		AS568-030 (fluorocarbon hardness Hs70)								
Mass	TA :Female thread rod	kg	4.0	3.9	4.5	4.4	5.1	5.0	5.6	5.5
	PA :Pin rod	kg	4.0	3.9	4.5	4.5	5.1	5.0	5.6	5.6
	MA :Male thread rod	kg	4.1	4.1	4.7	4.6	5.2	5.2	5.8	5.7

CNA25-Stroke		20	30	40	50	60	70	80	90	
DA	mm	58.5		78.5		98.5		118.5		
DB	mm	51		71		91		111		
DC	mm	57.5		77.5		97.5		117.5		
DD	mm	80		100		120		140		
DE	mm	86.5		106.5		126.5		146.5		
DF	mm	112.5		152.5		192.5		232.5		
DG	mm	62		82		102		122		
DH	mm	75.5		95.5		115.5		135.5		
øDJ	mm	101								
øDK	mm	52 <sup>-0.030</sup> <sub>-0.060</sub>								
øDL	mm	52 <sup>+0.039</sup> <sub>0</sub>								
øDM	mm	52.6								
øDP	mm	52								
O-ring		AS568-032 (fluorocarbon hardness Hs70)								
Mass	TA :Female thread rod	kg	6.6	6.5	7.5	7.4	8.3	8.3	9.2	9.1
	PA :Pin rod	kg	6.6	6.5	7.5	7.4	8.4	8.3	9.3	9.2
	MA :Male thread rod	kg	6.9	6.8	7.8	7.7	8.7	8.6	9.6	9.5

**Air sensor**

Supplier and model	ISA3-G series manufactured by SMC
	GPS2-05 series manufactured by CKD
Air supply pressure	0.2 MPa
Inner diameter of piping	ø4 mm
Overall piping length	5 m or less

- Supply the dry and filtered air. Particulate size 5 μm or less is recommended.
- Use a solenoid valve with needle for air sensor unit and control it supplying air all the time in order to eliminate intrusion of chips or coolant.

- There is a case that air sensing cannot be successfully made as designed when it is used out of the usage shown on the left. Contact Technical service center for more details.
- Refer to the sensor supplier's instruction manual for the details of setting.
- Sensing performance such as detectable time and pressure differs depending on the supplier and model number of the sensor. Select the right model referring to sensor's application and characteristics.
- Maximum 6 pieces of clamp can be detected at 0.2MPa air pressure by means of 1 piece of sensor. In case of 0.1MPa air pressure, maximum 3 piece of clamp are detectable.

**Air sensor triggering point**

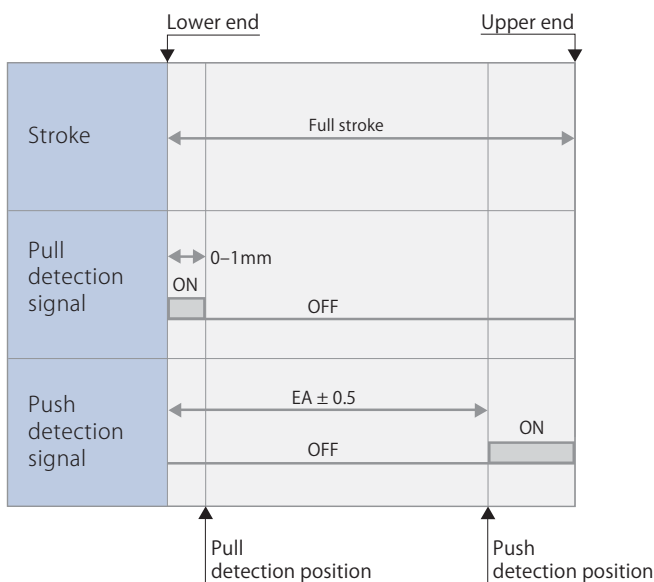

CNA02-Stroke		10	15	20	30	40	50	mm
Push detection position	EA(A1)	9	14	19	29	39	49	
	EA(A3)	7	12	17	27	37	47	
	EA(A5)	5	10	15	25	35	45	

CNA04-CNA06-Stroke		10	15	20	30	40	50	60	70	mm
Push detection position	EA(A1)	9	14	19	29	39	49	59	69	
	EA(A3)	7	12	17	27	37	47	57	67	
	EA(A5)	5	10	15	25	35	45	55	65	

  

CNA10-CNA16-Stroke		10	20	30	40	50	60	70	80	mm
Push detection position	EA(A1)	9	19	29	39	49	59	69	79	
	EA(A3)	7	17	27	37	47	57	67	77	
	EA(A5)	5	15	25	35	45	55	65	75	

CNA25-Stroke		20	30	40	50	60	70	80	90	mm
Push detection position	EA(A1)	19	29	39	49	59	69	79	89	
	EA(A3)	17	27	37	47	57	67	77	87	
	EA(A5)	15	25	35	45	55	65	75	85	

**Hydraulic and pneumatic circuit diagram**



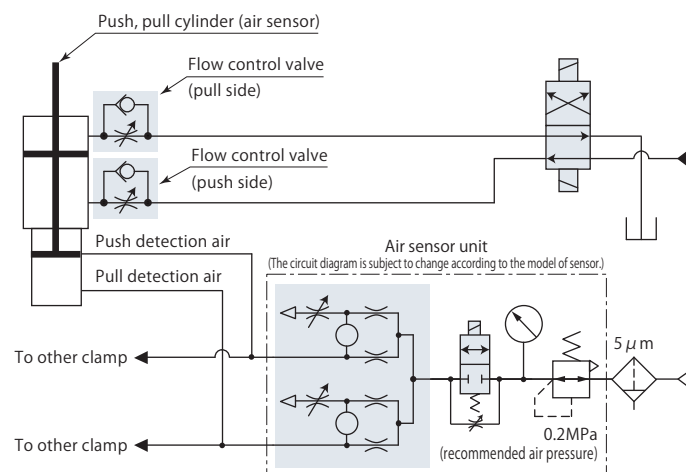

Caution in use

Please avoid the usage that may apply eccentric load and non-axial force to the piston rod.  
This may break the piston rod.

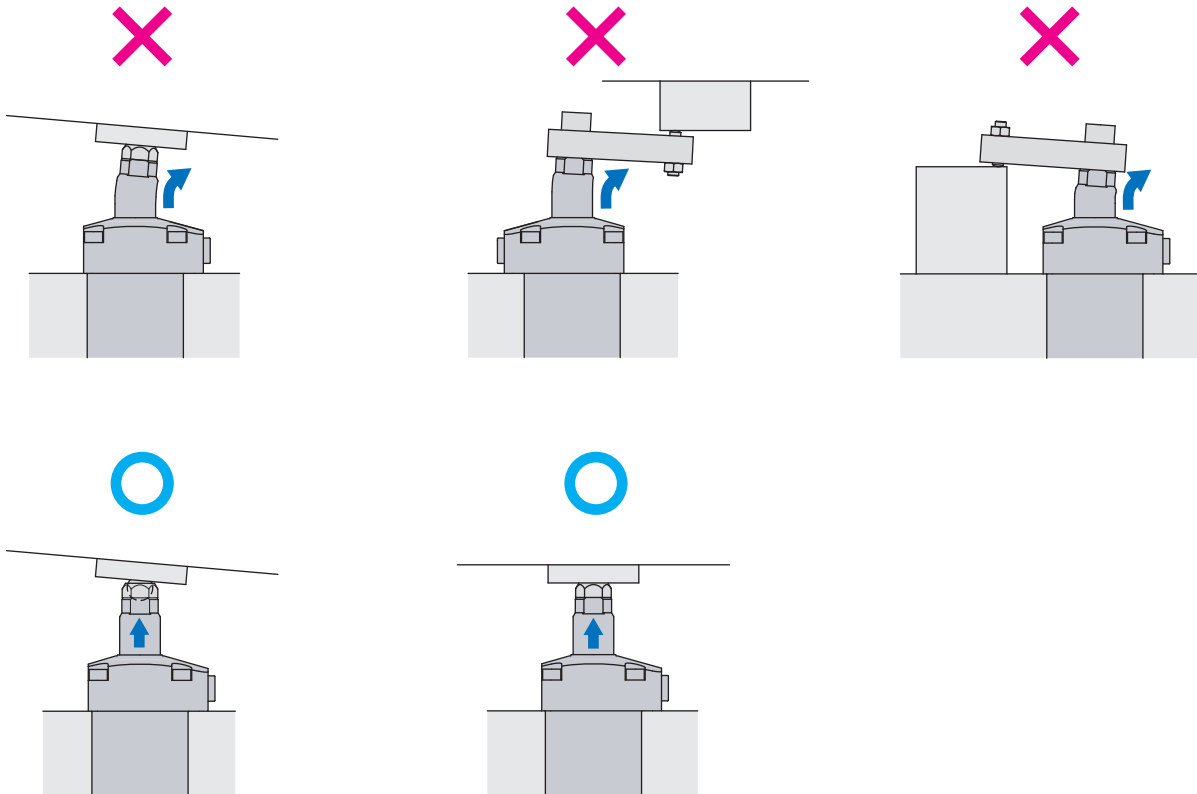
Female thread rod and male thread rod CNA□-□T, □MPin rod CNA□-□P